



FÉDÉRATION INTERNATIONALE
DE MOTOCYCLISME



CTR/CTI INFO 01/2019

19.03.2019

**2019
FIM Trial World Championship & Prizes
Main Information**

Dear Participant, dear Rider, Assistant, Manager, Manufacturer, FMN Delegate,

The 2019 FIM Trial World Championship season will begin soon and we would be happy to see you participating.

For this new season the FIM and its various services are responsible for the organization and control of its Trial World Championships. For this purpose, it has called on service providers and associative and private partners. Our objectives are to further improve the conditions of our events in sports, logistics and relationships.

We inform you that the 2019 Trial and Technical Regulations are online on:
<http://www.trialgp-noticeboard.com>

You will find some information below regarding the main changes or reminders within these regulations.

Online registrations are again open on the website: www.trialgp-registration.com

For those who have already made their entries, they can request the artwork and guidelines to print their shirts at office@trialgp.com

Team Licences will be available until 30/04/2019. Requests at licences@fim.ch

Thank you for your involvement in our various Championships, we remain at your disposal for any other useful information.



The information provided in this letter is not exhaustive and cannot prevail over the FIM regulations which are the only ones applicable during the FIM Trial World Championship Competitions.

Main information for 2019 FIM Trial regulations:

- Deadline for entries (Art. 2.2)
- Impossibility to change an assistant once the competition has started (Art. 2.6)
- Equipment / Back and knee protections for Riders, Assistants, Managers and any other person on a Motorcycle (Art. 2.8)
- Riding a motorcycle inside the paddock (Art. 2.10, 2.11, 2.12)
- A Team can register with only 1 rider (Art. 2.12)
- The use of the Team Manager bib (Art 2.12)
- Presence of a FIM Championship Manager (Article 4.21)
- Role of the FIM Race Director during Qualification (Art 4.9)
- Conditions for changing a Machine (Article 5.4)
- Assistance Area - PA2 (Art 5.4.3)
- Absence during Qualification (Art 5.12)
- Classification of Qualifications (Art 5.12.2)
- Penalty points for faults; Penalties for faults in Qualification. Penalties for absence during Qualification (Art 5.19.2.1)
- Penalty points for faults in a Section (Art 5.19.2.3)
- Ties at the end of a Competition (Art 5.26.1)

- **Trial des nations / Women's Trial des Nations**
 - Particular conditions:
 - Possibility of a Rider or Assistant to also be a Manager (Art. 2.12)
 - Possibility that a Rider assists another Rider subject to acceptance by the Race Direction (Art. 2.6)
 - Leaving the Event. Penalties when a Rider of a Team leaves the Event (Art. 5.16)
 - Penalty Points / Penalties at a Time Control (TC). Attribution of Penalty Points to a Team (Art. 5.19.1)

The changes to the Trial Technical Rules are applicable as of 01.01.2019 (Version 0) and from 07.03.2019 (Version 1). The list of modified Articles is given below:

| YEAR 2019 | | |
|-----------|--------------------|--|
| Version | Applicable as from | Modified articles |
| 0 | 01.01.2019 | 19.01, 19.04, 19.05, 01.29, 31.01, 31.02, 35.01, 39.01, 41.03, 41.04, 01.43, 49.08.2, 50.02.3, 50.02.4, 50.04.5, 01.63, 65.01, 65.02, 65.03, 65.04, 01.67, 69.02, 01.70, 77.01, 77.02, 77.04, 79.01, 79.02, 79.03, 79.04 |
| 1 | 07.03.2019 | 63.01 |

These Articles concern the following main subjects:

- **Art. 19.01** Clarification for minimum motorcycle weight as a function of capacity instead of class.
- **Art. 01.29** More detailed requirement for countershaft sprocket guard, which should cover both lower and upper chain runs.

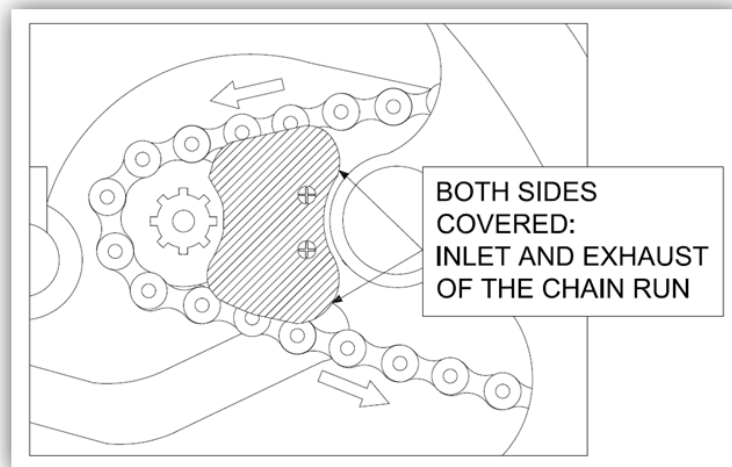



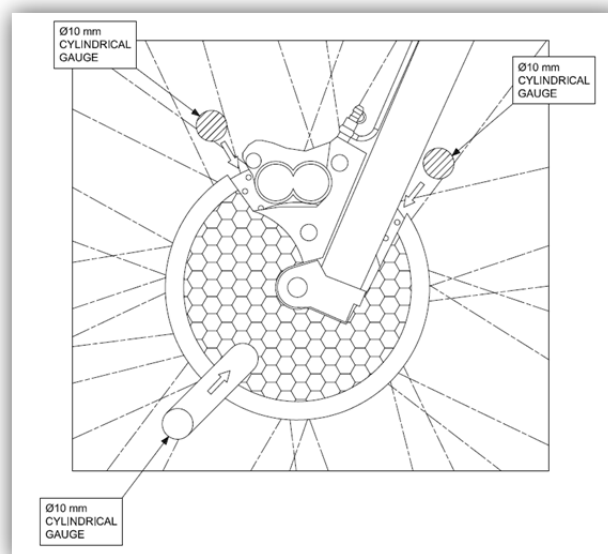
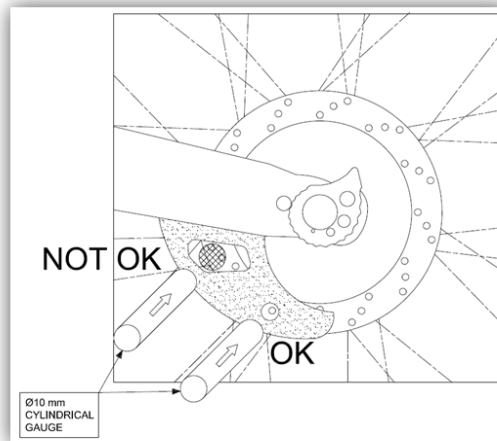

- **Art. 31.01** Greater freedom for the angle between silencer axis and principal longitudinal vehicle planes (brought from 10 to 15°).
- **Art. 35.01** Additional requirement for gear levers consisting of a tube: rounded edge.
- **Art. 39.01** Additional requirement for footrest teeth: avoid sharp edges and, as of 2020, maximum teeth height of 10 mm.
- **Art 41.03** Simplification of requirements for rear brake disks openings: a gauge up to 6 mm should be able to block any of those.
- **Art 41.04** Simplification of requirements for front and rear brake disk cover openings: a gauge up to 10 mm should be able to block any of those. It is reminded that a full cover must be present at the front and a partial at the rear; a full cover is only required at the rear if the rear brake disk openings do not fulfill Art. 41.03.

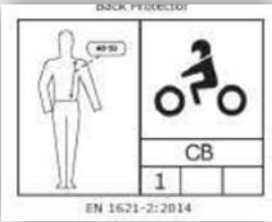
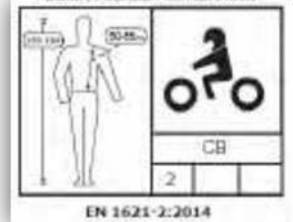

- **Art. 01.43** Additional requirement for mudguards: rounded edges.
- **Art. 49.08.2** Clarification on tyre markings.
- **Art. 50.02.3-4** Additional requirements for power supply specifications and Pit Stop/Assistance Area PA2 in case of Trial-E races.
- **Art. 50.04.5** Clarification on the position of power indicator front light for electric motorcycles.
- **Art. 01.63** New procedure and clarifications for gasoline specifications and tests.
- **Art. 63.01** Clarification on allowed ethanol content for gasolines.
- **Art. 65.01** Introduction of compulsory
 - back protector complying with EN 1621-2, CB ("central back") or FB ("full back"), Level 1 or 2: see labels below
 - knee protector.

for riders, their Assistants and Team Managers. It remains recommended to wear chest and elbow protectors

| Newer labels (1621-2:2014) | | |
|----------------------------|--|---|
| Full Back Level 1 or 2 |  |  |
| Central Back Level 1 or 2 |  |  |
| Older labels (1621-2:2003) | | |
| Full Back Level 1 or 2 |  |  |



FÉDÉRATION INTERNATIONALE
DE MOTOCYCLISME



- **Art. 69.02** New procedure for Technical Stewards finding a defective or non-conform helmet: red marking on international labels without destroying them and retaining of the helmet until the end of the event.
- **Art. 77.02** Clarifications on
 - FIM stickers position
 - procedure for motorcycles unable to continue the event (faulty frame or engine)
 - procedure for damaged silencers or fuel tanks
 - change of non-marked components during the event.
- **Art. 79.01** New requirements for sound meters specifications and accuracy of the method tolerances (not anymore based on Classes, but on frequency response).
- **Art. 79.02** New requirements for ambient sound during sound tests.
- **Art. 79.03** Clarifications on sound test procedure: the "max rpm" is established at 10000 (± 200) rpm and obtained thanks to a dedicated "sound test" mapping of the internal ECU or an external one, purpose-made and connected in occasion of the test.
- **Art. 79.04** Clarifications on the rounding method of sound measured values.

The latest updates of the 2019 Trial Technical Rules can be found [on the FIM website](#) or the [TrialGP Noticeboard](#).