

SUPPLEMENTARY REGULATIONS

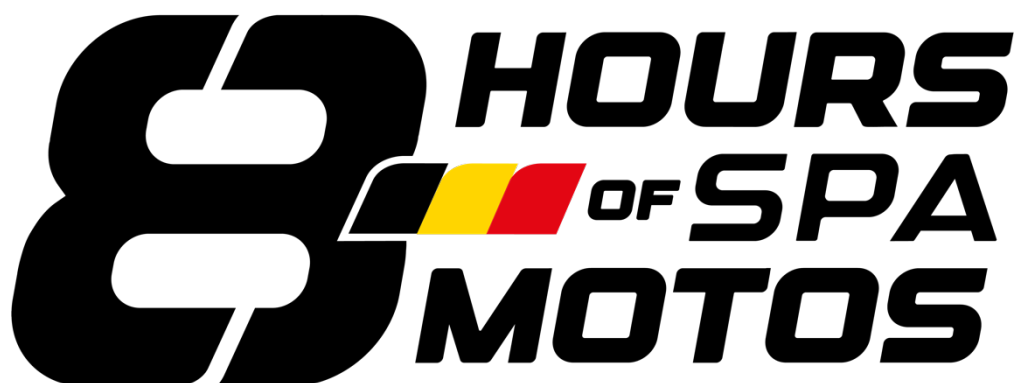

June 7th – 8th 2024

Circuit of Spa-Francorchamps

SUBJECT TO ADMINISTRATIVES AUTHORIZATIONS



Article 1 – PUBLICATION

Name of the Event: **8H Spa EWC Motos**

National Sporting Authority:

Fédération Motocycliste de Belgique asbl. Chaussées de Louvain 550 boîte 7 à 1030 Bruxelles
Tel: +32 2 736 53 97

International Sporting Authority:

Fédération Internationale de Motocyclisme 11 Route Suisse – 1295 Mies (Switzerland)
Tel: +41 22 950 95 00

Definition of the Event:

International event counting for the 2024 FIM Endurance World Championship and Cup.
This event will be held on 7th and 8th, June 2024.

It is entered in the FIM Calendar with ref IMN 104/02

Organizer:

PHA – Claude MICHY

Address:

PHA
15 bis place Renoux
63000 Clermont-Ferrand

Article 2 – SECRETARIAT OFFICE OF THE ORGANISATION

PHA
15 bis place Renoux
63000 Clermont-Ferrand

During the event
Le Circuit de Spa-Francorchamps,
55, route du Circuit
4970 STAVELOT
E-mail : event@pha-michy.com

Article 3 - CIRCUIT

Length of Circuit Spa-Francorchamps: 6,985 km / 4,340 miles (Appendix 13).
The race will be run clockwise during 8 hours.

Access to the Track for teams' setup will be authorized exclusively by Blanchimont entrance from Tuesday June 5th 09.00 a.m. (Appendix 14). A waiting area will be set up Tuesday "waiting area", in order to wait until your call to enter the paddock. The positioning of the competitors in the pits and in the paddock will be subject to prior authorization from the organization. An hourly convocation of each competitor may be imposed by the organizer. In the event of non-compliance with the convocations, sanctions may be taken (report from the organizer to the sporting authority).

Leaving the Circuit: the paddocks and pits must be vacated no later than Sunday midday (12:00 p.m.) in order to allow the site to be cleaned and not block the entry of subsequent users.

It is forbidden to fit any metal objects in our asphalt surfaces such as tent pegs, nails...
In case of non-respect, sports or financial penalties will be applied.

It is formally forbidden to use the track or its immediate approaches with any machine whatsoever, except during Practice Sessions and Races

Article 4 – JURISDICTION

The Event will be organized in accordance with the Endurance World Championship and Cup Regulations of the FIM, the prescriptions of the CCR/FIM, and with these Supplementary Regulations. The organizer also undertakes to respect as much closely as possible the FIM Environmental Management Plan.

Article 5 – OFFICIELS

PERMANENT OFFICIALS / INTERNATIONAL JURY

Race Direction

Race Director : COUTANT Patrick

Safety Officers FIM : DELETANG Jean-Marc

Warner Bros Discovery Sports Representatives : VALERIANI Dorian / JEANFILS Renaud

FIM EWC Stewards

Chairman: MAAS Simon

FIM EWC Steward 2 nominated by FIM : BRICE Gerry

FIM EWC Steward 3 nominated FIM : EEKELLEN Arian van

Appeal Steward panel

Appeal Steward nominated by the FIM: KING Paul

Appeal Steward nominated by the FMB: DOBBELAERE Philippe

FIM Technical Directors

REIGNIER Ludovic – SCHENKHUT Bernd – SANCHEZ Miguel

FIM Medical Director : MC MANUS David

Secretary of the Jury: RENTMEESTERS Stijn

DELEGATED OFFICIALS

Clerk of the Course: DEQUESNE Jean-Luc

Deputy Clerks of the Course: VANHOOTEGHEM Philippe

Environment steward: MARTIN Olivier

FMB Scrutineer officer: THIRYON Jean-François

Secretary of the scrutineering: ROELS Patrick

FMB Scrutineers: DEFRENNE Daniel

Track Safety Officer: Circuit Spa-Francorchamps

Medical Chief Officer: TBC

Timekeeping: ITS EVENTS SULEAU Quentin

Representative of the Organisation: MICHY Claude

FIM Coordinator: NAZAROVA Svetlana

Article 6 - NUMBER OF MOTORCYCLES ADMITTED

Motorcycles admitted to practices and race: 60 (subject to the homologation of the circuit)

Article 7 - ENTRIES - RIGHTS

The Selection Committee composed with 4 representatives of: PHA / FIM / FMB and WBDS will carry out, on the basis of the entry request received at the closing date, a selection of 60 teams invited to attend the Administrative Checks and the Scrutineering

The entries must be made according to the following priority: FIM Endurance Regulations Article 1.10.8: 2 places will be granted for teams entering a machine in the "Experimental" class provided that they meet the requirements of Article 2.9 and the agreement of the FIM Endurance Technical Director.

The selection Committee reserves the right to refuse an entry, even if received within the deadline.

Request for entry must be made on the official Entry forms of the organizer (PHA).

→ **Closing Date: MAY 24th 2024, midnight**

Entry forms must be enclosed with the following documents:

- The proof of payment (copy of the bank transfer).
- The information form (attached with the entry form) which must be carefully filled in, otherwise the entry request will not be considered.
- The records of wins certified and provided by the FMN, for all the riders.
- **For the team's registration, the entry form must include, at the least, the name of 2 riders for the 8H races.**
The riders must be part of the team registered at the administrative control, except in the case of force majeure

The participation fees per motorbike is € 1 900 and must be paid by means of credit transfer only by MAY 24th 2024 at the latest, failing which the entry will not be considered by the Selection Committee (Bank check will be refused).

Crédit Mutuel						
RELEVÉ D'IDENTITÉ BANCAIRE						
Identifiant national de compte bancaire - RIB						
Banque	Guichet	N° compte	Clé	Devise	Domiciliation	
10278	11608	00020140919	58	EUR	CCM CHAMALIERES	
Identifiant international de compte bancaire						
IBAN (International Bank Account Number)				BIC (Bank Identifier Code)		
FR76	1027	8116	0800	0201	4091	958
Domiciliation				Titulaire du compte (Account Owner)		
CCM CHAMALIERES				PHILIBERT ET ASSOCIES		
30 B AVENUE DE ROYAT				MR CLAUDE MICHY		
63400 CHAMALIERES				19 RUE DU PORT		
☎ 04 73 30 91 60				63000 CLERMONT FERRAND		
Remettez ce relevé à tout autre organisme ayant besoin de connaître vos références bancaires pour la domiciliation de vos virements ou de prélèvements à votre compte. Vous éviterez ainsi des erreurs ou des retards d'exécution.				PARTIE RESERVEE AU DESTINATAIRE DU RELEVÉ		

WITHDRAWAL

Any declared withdrawal is irrevocable. The Team Manager of the Team must give written notification to WBDS, by email: operations@fimewc.com

In this case, the entry fee (€ 1 900) shall be retained by the organizer.

An entry request becomes definitive only after the Entry form, the entry fee and the deposit have been received and becomes an Official Entry only after the invitation have been received by the Organizer for the Administrative checkings and Scrutineering.

Article 8 - ADMINISTRATIVE CHECKINGS, SCRUTINEERING AND BRIEFINGS

Administrative Checkings Digital scrutineering:

Scrutineering:

Wednesday June 5th in the teams' garages

Timetable: **9.00 a.m - 4.00 p.m** according to the scrutineering timetable

Please respect your summon times

Team Managers & Riders' Briefing:

Thursday June 6th from 6.30 p.m to 7.15 p.m - CIRCUIT, LOCAL 132

Mandatory briefing for all team managers and for riders who have not participated in a World Endurance Championship round in 2024.

Article 8.1 – NOT APPLICABLE FOR 2024

Article 9 - TIMEKEEPING UNIT (TRANSPONDER)

Competitors must install the rental transponder provided by the Organiser on the motorcycle. Rental transponder will be remitted by the timekeeping company (ITS EVENTS), during the Scrutineering

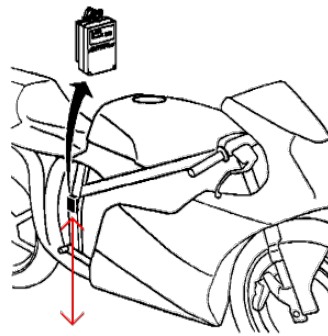

Must be installed not higher than 60 cm from the ground surface.

Please note that it may not be possible to record a time if the transponder is not mounted in a correct manner/position.

The team will have to give back the transponders to the timekeeping company (ITS Chrono) (1st floor of the Pit Building – Room 120) put at their disposal, either after withdrawal or at the latest 10 minutes after the end of the race, if the motorcycle has finished the race.

In the case of non-return of this equipment, the unreturned item will be deducted from the technical costs deposit.

Article 10 – STARTING PROCEDURE (« LE MANS » TYPE)

Start ceremony: the Competitors and the riders have to be available and absolutely respect the program of all the planned ceremonies by the Organizer (protocol announced in the Riders' and Team managers' briefing).

Article 11 - ASSISTANCE DURING THE RACE

If a team so wishes, it can ask for assistance for the rider and its motorcycle to be taken back in a vehicle provided by the organizers.

In that case, both will be dropped at a location to be confirmed during the briefing.

From this point, 2 people from the team are allowed to bring the machine back to the pits under a track marshal control. His lap will not be counted in his end-of-race total. If several teams ask for such assistance following a problem involving a number of riders, the teams will be assisted in the order of the starting grid.

Vehicles will be available on the track for this use.

No other assistance than the one from the organizers will be permitted.

Article 12 – FUEL AND REFUELING

The fuel used will be the one provided by the promotor.

Control of the refuelling systems:

The refuelling systems (**FIM Homologated**) will be checked by the scrutineers.

All refuelling systems will be obligatory checked on **Wednesday 5 June from 9.00 a.m. to 4.00 p.m.**

Should the refuelling system not have been approved by the FIM scrutineers, the competitors will not be able to take part in the free practice sessions on Friday June 7nd.

Refuelling operations must comply with the Endurance FIM Regulations in force.

The storage of fuel in the stand may not exceed 60 litres (derrick content included).

It is strictly forbidden to smoke in front and the stands.

It is prohibited for the person assigned to the fire safety of wearing official fireman.

Lighting devices of lighting cannot be fixed on the support of the autonomous fuel tank.

Any electrical installation located at less than 3 meters from the autonomous pit tank must be anti-explosion. Only low temperature and anti-explosion lights are authorised, halogen lights are forbidden

Refueling System

Refer to article 2.3.15 of the 2024 FIM Endurance World Championship Regulations as well as to the « Refueling System », Appendix 09)

Article 13 – PRIZES

The prizes are the subject of the contract between WBDS, the organisers and the teams.

The prizes will be sent - by bank transfer - on the account from which the payment of the entry fee was made.

Article 14 - PRIZE-GIVING AND CUPS

Trophies and Cups will be presented on the Podium.

Article 15 – PROTESTS AND APPEALS

The protests and appeals will be formulated in accordance with the FIM disciplinary code and recommending regulations (see Article 3.4 of the FIM Endurance World Championship and Cup Regulations).

Article 16 - INSURANCE

By approving of the entry form, the riders' FMN of the rider certifies that he is personally insured in compliance with the FIM Code.

The organiser has taken out an insurance policy covering the liability of the riders in the event of accident (s) occurring during the Event (both the race and the practice sessions). A copy of the contract is available upon request. The organiser can not to be held responsible for damages caused to a motorcycle, accessories or equipment through accident, fire or any other causes.

Article 17 - RELINQUISHING ALL RIGHT OF APPEAL AGAINST THE SPORTING AUTHORITIES

Independently of the FIM Sporting Code status, riders by the mere fact of their participation, waive their rights of appeal against the organisers, its representatives or employees, whether through arbitration, law courts, or any other means not specified in the FIM Sporting Code, for any damage to which they may be exposed as a result of any act or omission committed by the organiser, his officials, representatives or employees, in the

application of these rules, or any rules which might be brought into effect at a later date, or for any cause which may be a result of this.

Article 18 - POSTPONEMENT/Cancellation of the Event

Should circumstances or safety reasons demand it, the 8H Spa EWC Motos Event could be postponed or cancelled. For this the PHA organiser will not be held responsible. Should this occur, the association undertakes to refund only the entry fee.

APPENDIXES

1 - SIGNALLING AREA

The signalling area is in the pit lane.

Signalling:

The maximum dimensions possible for signalling facilities are the following:

Height : 2.00 m above track level,

Width: 2.00 m along the signalling wall,

Depth: 1.00 m from the wall track side

The timing pit board cannot exceed the glass protection. Under no circumstances, can it be positioned above the glass. No drilling is allowed on the supporting frame of the glass protection.

Penalties: at FIM Stewards' Discretion

2 - PIT AREA

It is regulated and controlled.

The wearing of the helmet is mandatory in the pit lane during the practice sessions and the race.

Pit Stops: the team members holder of the official credentials are permitted in the working area in front of their pit box only just before working on the motorcycle. They must leave the pit- lane as soon as the work is finished.

Except during these interventions, the team members cannot stay in the pit lane.

3 - ADVERTISING

Advertising on motorcycles and on riders' overalls must comply with the FIM/FMB regulations.

Advertising and promotional action or public relations is possible after a written agreement with the Circuit Spa- Francorchamps and PHA.

4 – PASSES/ACCREDITATION

The teams under contract will receive their passes from the Promoter of the FIM Endurance World Championship and Cup.

Other teams will get a maximum of 30 passes per motorcycle, admitted to take part in the practice sessions.

16 "PIT LANE" nominative accreditations

1 for the Team Manager

1 for each rider (maximum 4)

4 for mechanics

4 for the signalling area

2 for the people in charge of the refuelling

1 for the person in charge of the safety during the refueling (firefighter).

14 "PADDOCK" passes

For the staff of the Team, Partners, Guests, etc.

7 Car-park passes (6 parkings outside of the Paddock and 1 parking in the paddock) per motorcycle allowed to take part in the practice sessions.

6 – FACILITIES AND ALLOCATION OF PITS

Allocation of facilities:

e-mail: event@pha-michy.com

Each team will be allocated:

- 1 pit
- 1 space for the workshop in the working paddock (15 X 3 m),
- 1 space on support in the support paddock (of 180 m² approximatively).

The set up in the support/working paddocks must be approved by the organizer/promotor.

The private cars are strictly forbidden and must be exclusively park in the authorized area.

Allocation of pits is under the Organiser's exclusive responsibility: 40 F1 pits (1 box per motorbike) and 40 Endurance pits (2 boxes per motorbike) will be available.

Pits will be allocated according to the requests and dates of receipt of entries.

Documents enclosed below:

7 – Timing.

8 – Fuel characteristics

9 – FIM homologated fuel quick-fill system

10 –Short cuts

11– Map of the circuit

12– Location Map Accreditation Center

13 – Medical Center Access map

14 – Access to the track

In the case of dispute or controversy arising from the interpretation of the articles of these supplementary regulations, the French version only shall be deemed authentic.

07- TIMING



8H SPA MOTOS - TIMETABLE V6 - 30/04/2024

TUESDAY JUNE 04th			
09:00	20:00	FIM ENDURANCE WORLD CHAMPIONSHIP	Paddock Waiting Area Opening
20:00		FIM ENDURANCE WORLD CHAMPIONSHIP	Paddock Setup Start
WEDNESDAY JUNE 05th			
14:00	20:00		Accreditation Center Opening
09:00	16:00	FIM ENDURANCE WORLD CHAMPIONSHIP	Scrutineering
12:00			Paddock Setup END
16:00	16:30	FIM ENDURANCE WORLD CHAMPIONSHIP	Parade : Circuit - Malmedy
16:30	18:00	FIM ENDURANCE WORLD CHAMPIONSHIP	Parade : Signing Session
18:00	18:30	FIM ENDURANCE WORLD CHAMPIONSHIP	Parade : Malmedy - Circuit
THURSDAY JUNE 06th			
08:00	13:00		Accreditation Center Opening
14:00	20:00		Accreditation Center Opening
07:00	08:55	FIM ENDURANCE WORLD CHAMPIONSHIP	Waiver Signature
07:30	08:55	FIM ENDURANCE WORLD CHAMPIONSHIP	Track Inspection
09:00	11:55	FIM ENDURANCE WORLD CHAMPIONSHIP	Private Practice
12:00	12:55	FIM ENDURANCE WORLD CHAMPIONSHIP	Break
13:00	17:55	FIM ENDURANCE WORLD CHAMPIONSHIP	Private Practice
16:00		FIM ENDURANCE WORLD CHAMPIONSHIP	Jury Meeting
18:30	19:15	FIM ENDURANCE WORLD CHAMPIONSHIP	Riders & Team Manager Briefing – Briefing Room
FRIDAY JUNE 07th			
08:00	13:00		Accreditation Center Opening
14:00	22:00		Accreditation Center Opening
08:15		FIM ENDURANCE WORLD CHAMPIONSHIP	Medical Inspection
08:30		FIM ENDURANCE WORLD CHAMPIONSHIP	Track Inspection
09:00	11:00	FIM ENDURANCE WORLD CHAMPIONSHIP	Free Practice Session
11:15	11:45	SUPPORT RACE	Qualifying Session 1
12:00	12:30	SUPPORT RACE	Qualifying Session 2
13:15	15:15	FIM ENDURANCE WORLD CHAMPIONSHIP	1 st Qualifying Practice Session
15:30	16:30	SUPPORT RACE	Race 1
17:00	19:00	FIM ENDURANCE WORLD CHAMPIONSHIP	2 nd Qualifying Practice Session
19:30	20:30	FIM ENDURANCE WORLD CHAMPIONSHIP	Pit Walk
SATURDAY JUNE 08th			
08:00	15:00		Accreditation Center Opening
08:15		FIM ENDURANCE WORLD CHAMPIONSHIP	Medical Inspection
08:30		FIM ENDURANCE WORLD CHAMPIONSHIP	Track Inspection
09:00	09:45	FIM ENDURANCE WORLD CHAMPIONSHIP	Warm Up
10:00	11:00	SUPPORT RACE	RACE 2
11:00	11:45	FIM ENDURANCE WORLD CHAMPIONSHIP	Pit Walk





12:00	FIM ENDURANCE WORLD CHAMPIONSHIP	Pit Lane Open	
12:05	FIM ENDURANCE WORLD CHAMPIONSHIP	Pine Lane Closed	
12:25	FIM ENDURANCE WORLD CHAMPIONSHIP	Grid Access Open	
12:35	12:45	COMMERCIAL	Animation
12:48	12:49	FIM ENDURANCE WORLD CHAMPIONSHIP	Belgium National Anthem
12:50	FIM ENDURANCE WORLD CHAMPIONSHIP	5' Board	
12:52	FIM ENDURANCE WORLD CHAMPIONSHIP	3' Board + Track Evacuation (except 1 mechanic per bike)	
12:54	FIM ENDURANCE WORLD CHAMPIONSHIP	1' Board	
12:54:30	FIM ENDURANCE WORLD CHAMPIONSHIP	30'' Board	
12:55	FIM ENDURANCE WORLD CHAMPIONSHIP	Green Flag	
12:59:30	FIM ENDURANCE WORLD CHAMPIONSHIP	FIM EWC Anthem	
13:00	FIM ENDURANCE WORLD CHAMPIONSHIP	Race Start	
21:00	FIM ENDURANCE WORLD CHAMPIONSHIP	Race Finish	

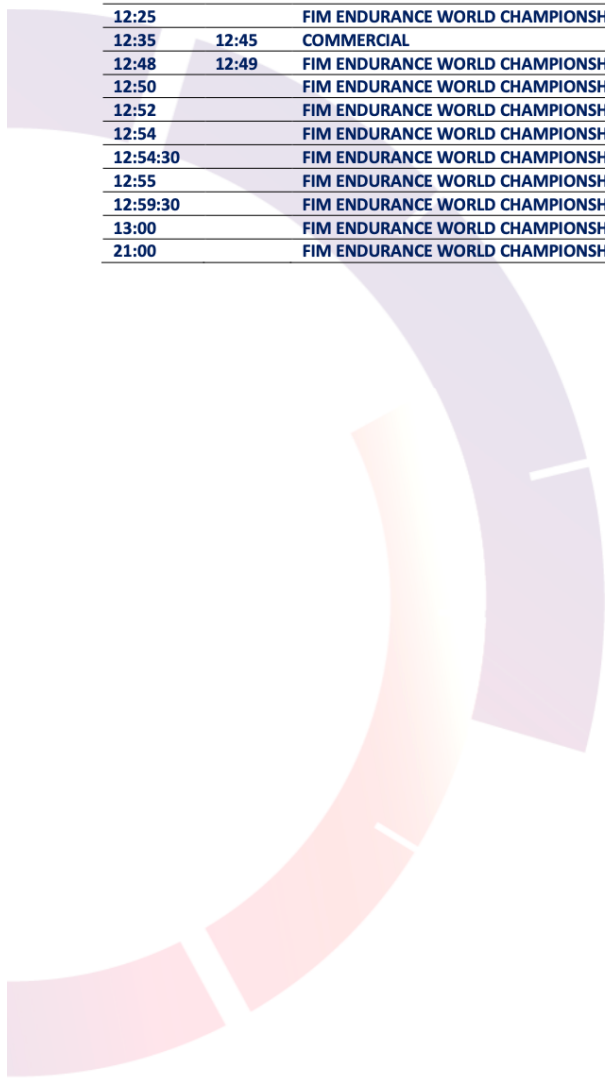

08- FUEL CHARACTERISTICS

Prix : TBC
 Unit Price : TBC

09- FIM HOMOLOGATED FUEL QUICK-FILL SYSTEM

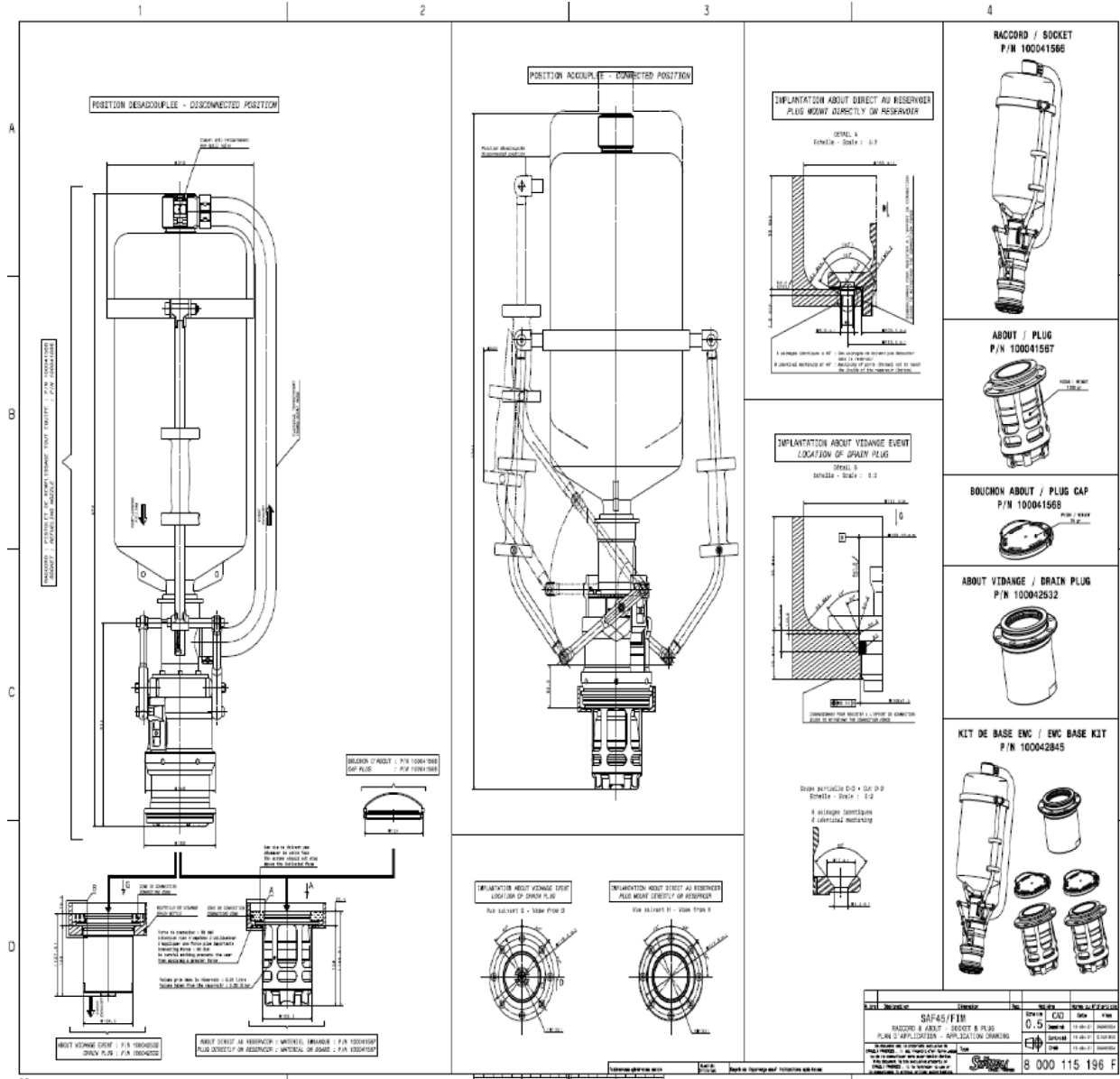

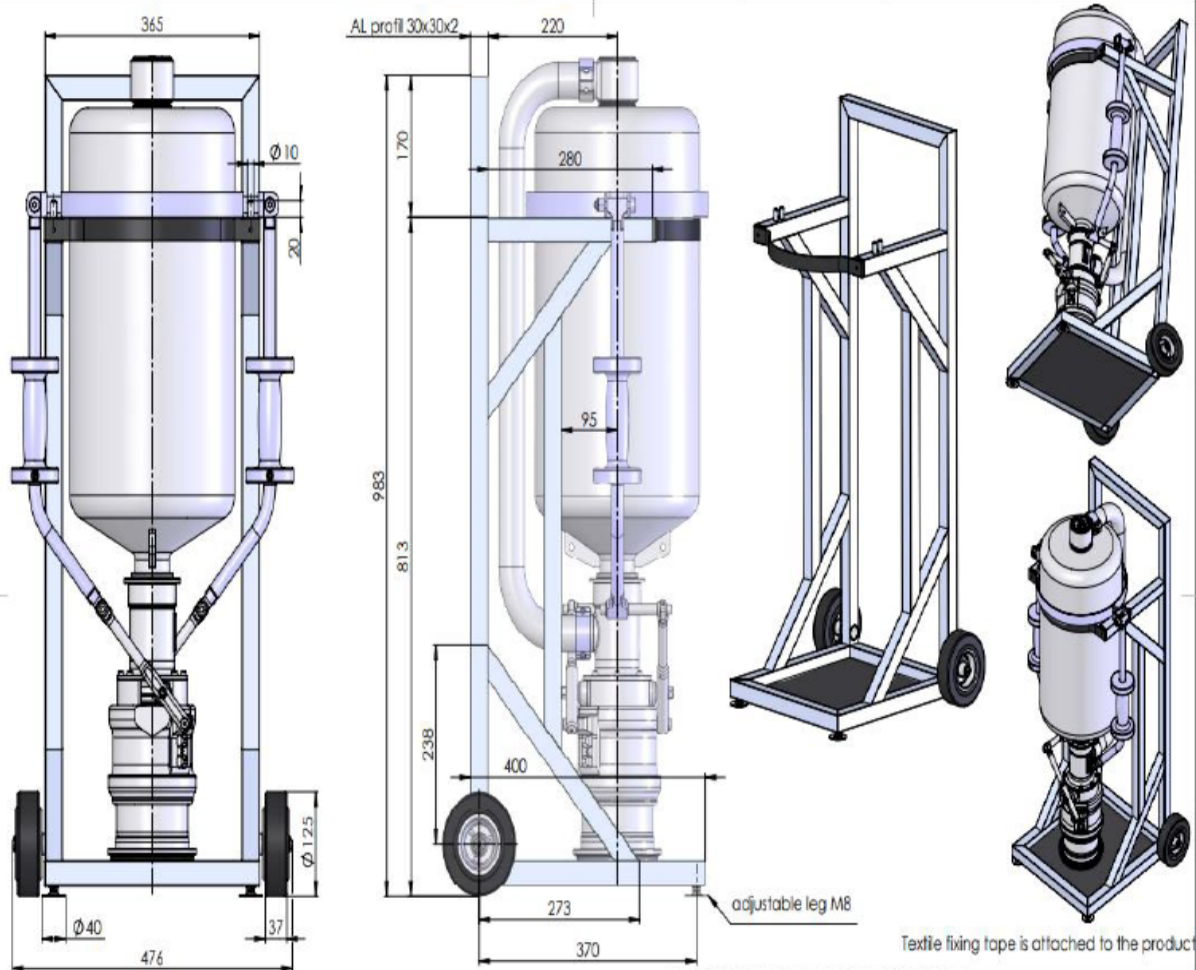

THE INFORMATION CONTAINED IN THE DRAWING IS THE SOLE PROPERTY OF CASELINER, s.r.o.
 ANY REPRODUCTION IN PART OR AS A WHOLE WITHOUT THE WRITTEN PERMISSION OF CASELINER, s.r.o. IS PROHIBITED.

CASELINER s.r.o.			
file - stock size:	dimension standard:	material standard:	part number: 0150121117
scale:	drawn: R. Lucak	surface finish:	UNLESS OTHERWISE SPECIFIED: DIMENSIONS ARE IN MILLIMETERS TOLERANCES: ISO 2768 - m
date:	17.2.2022	weight:	set size:
approved by:	projector:	location:	form day:
date:			
CASELINER s.r.o. Mlýnská 568 252 42 Vestec Czech Republic		title: BOTTLE TROLLEY ST25ENC	signature: 0150121117

Ordering contact:
Mr. Adam BELSKY / CASELINER / Project Manager / adam@caseliner.com / + 420 724 728 478

10 – SHORT CUTS

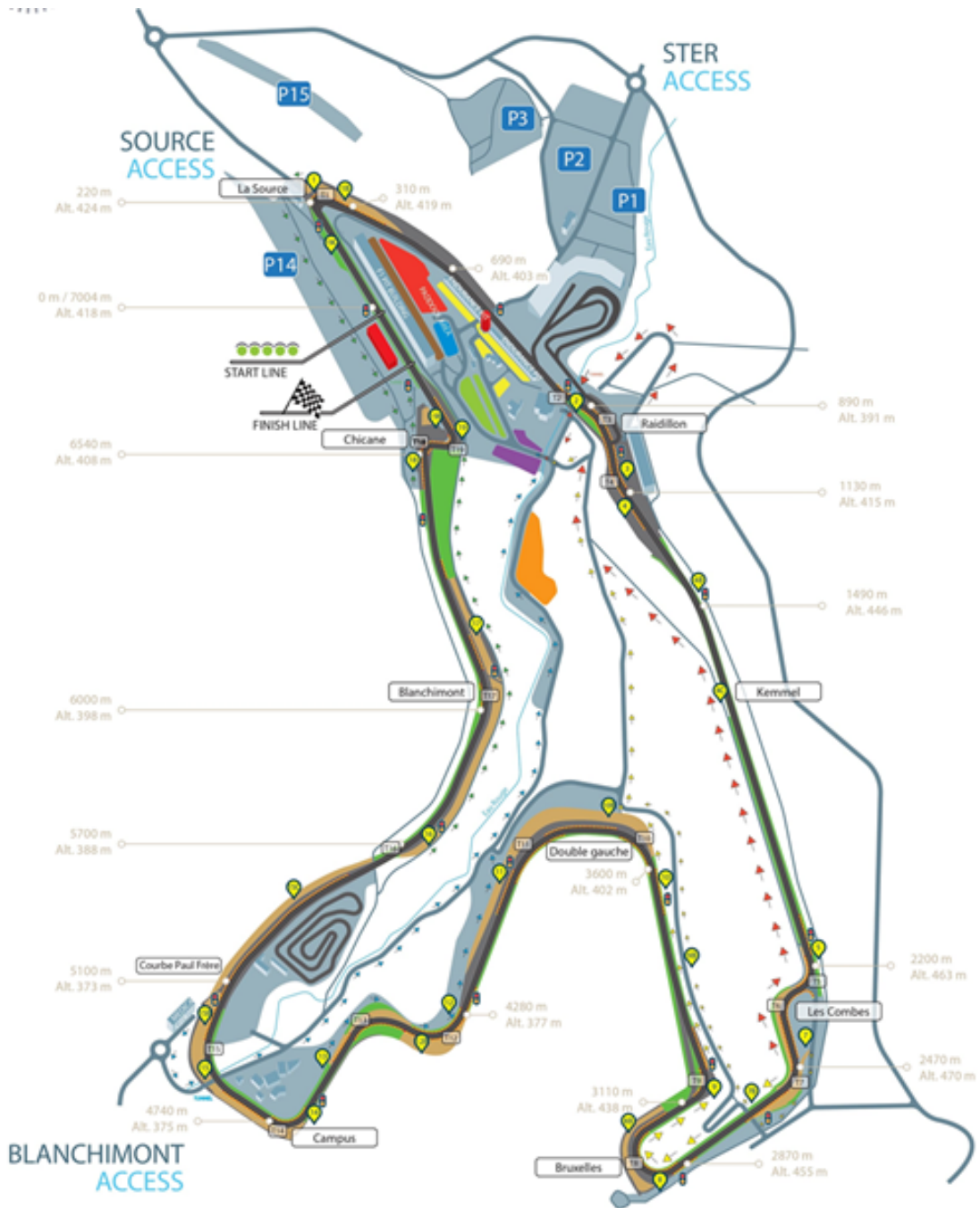

11- MAP OF THE CIRCUIT

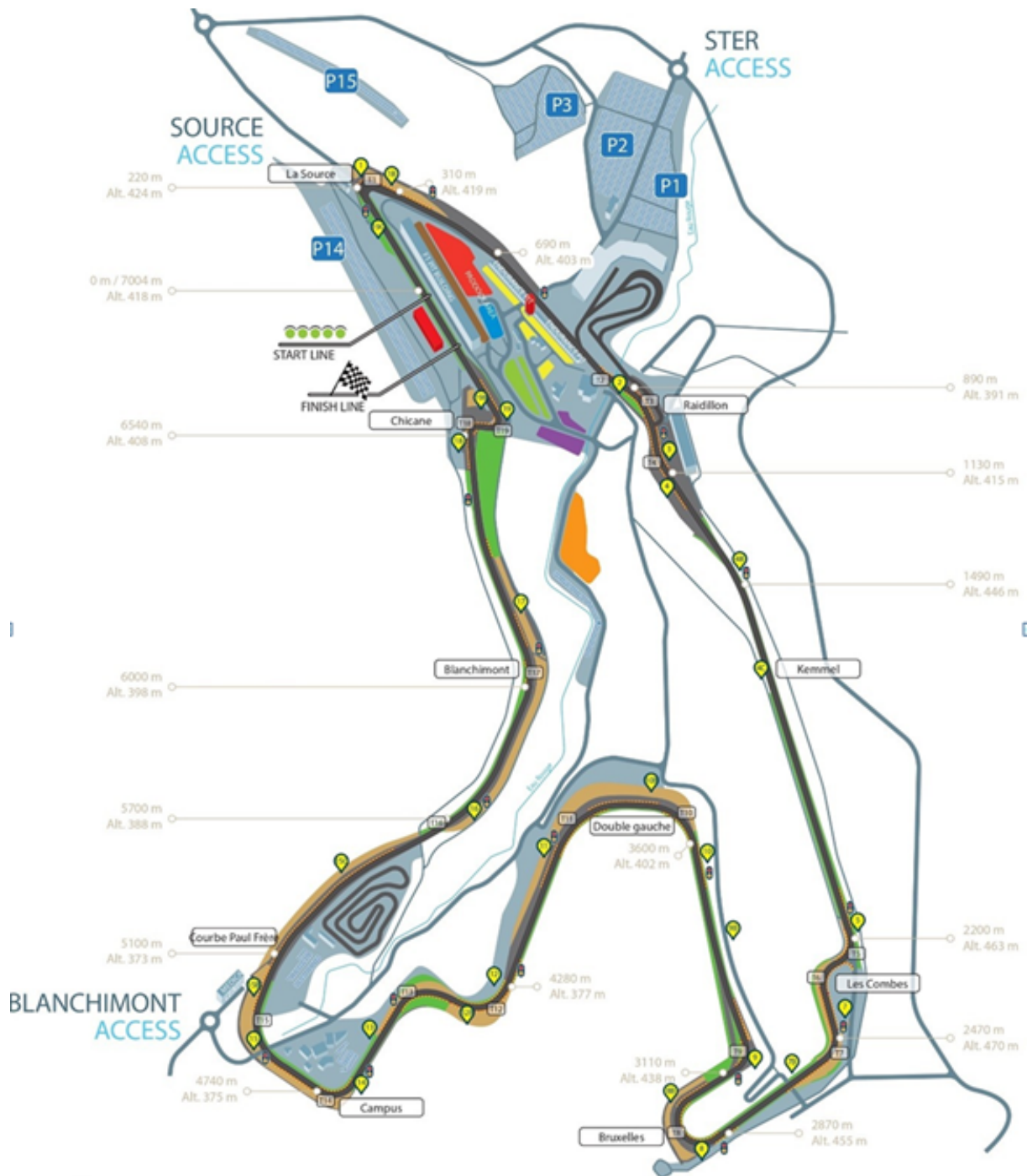

12- LOCATION MAP ACCREDITATION CENTER

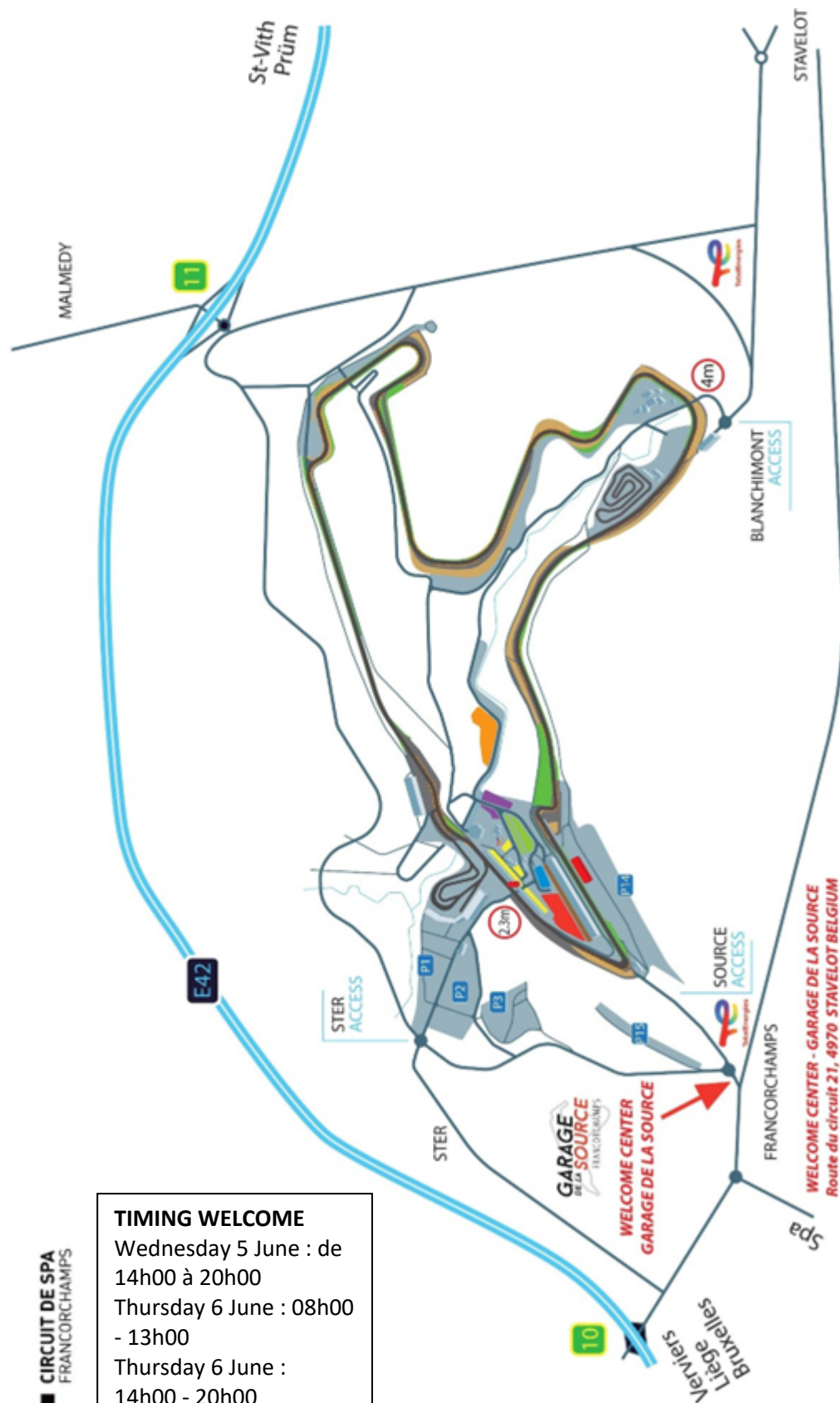

CIRCUIT DE SPA FRANCORCHAMPS

TIMING WELCOME
 Wednesday 5 June : de 14h00 à 20h00
 Thursday 6 June : 08h00 - 13h00
 Thursday 6 June : 14h00 - 20h00
 Friday 7 June : 08h00 - 13h00
 Friday 7 June : 14h00 - 22h00
 Saturday 8 June : 08h00 - 15h00

13 – MEDICAL CENTER ACCESS MAP

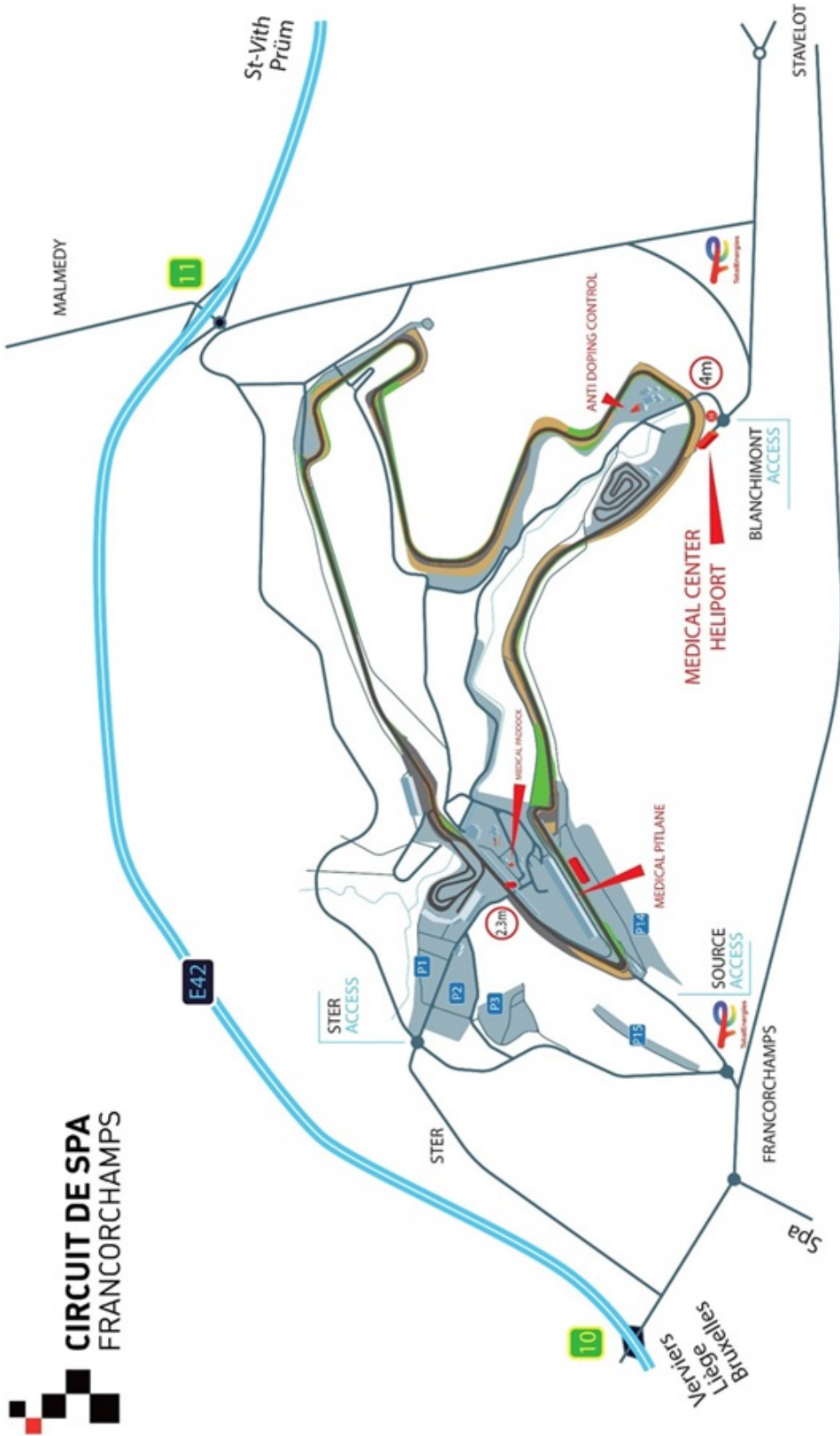

14 – ACCESS TO THE TRACK

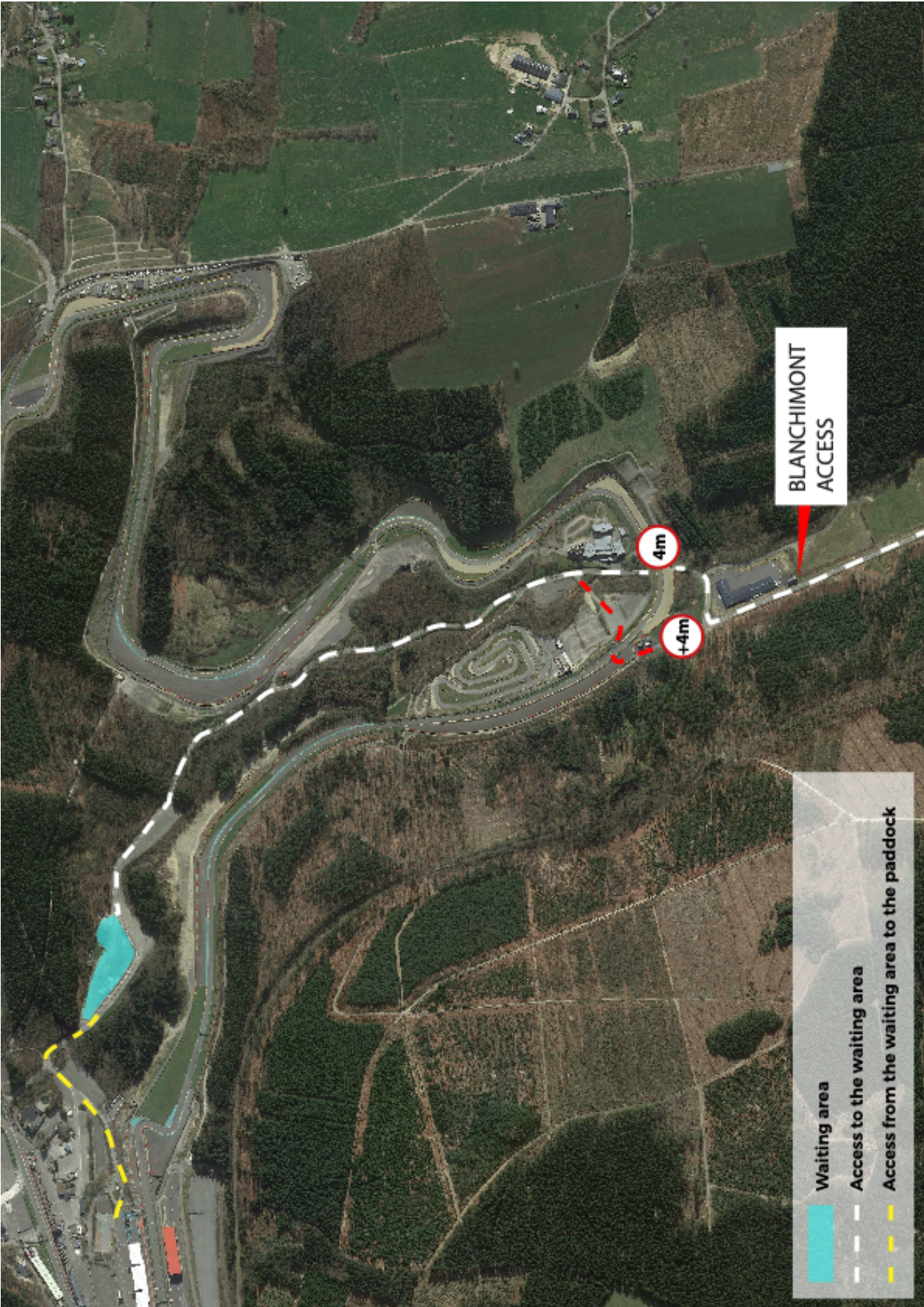

ENTRY FORM

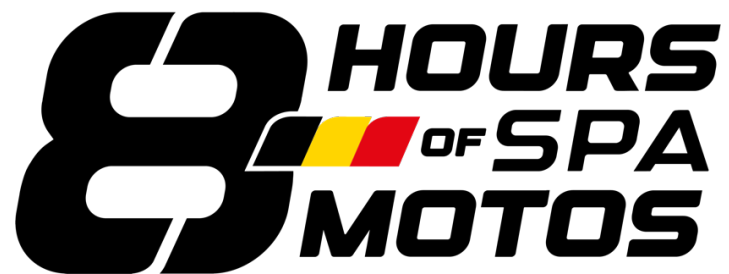

June 07th – 08th 2024

*To be sent before Friday 24th of May 2024
via e-mail to event@pha-michy.com*

STARTING NUMBER

*This number will be confirmed
after the registration deadline
for non-permanent teams.*

TEAM

ADRESS

MOBILE _____ **E-MAIL** _____

COMPANY NAME _____

VAT NUMBER _____

TEAM MANAGER _____ **LICENSE NR** _____

CATEGORY

Tick off the category in which you wish to take part.

- FORMULA EWC** (Cf. FIM *technical code*)
- SUPERSTOCK** (Cf. FIM *technical code*)
- EXPERIMENTAL** (Cf. FIM *technical code*)

MOTORCYCLE

BRAND _____

TYPE _____

Preferred Pit Lane allocation

- Pit Building**
- Endurance Boxes**

*Pit allocation will be confirmed after the closing entry date.
Non-permanent teams may share their box in pit building with another concurrent if needed.*

BLUE RIDER	Name		
	1st name		Nat
	Address		
	E-mail		
	Mobile		
	License Nr.		Federation

YELLOW RIDER	Name		
	1st name		Nat
	Address		
	E-mail		
	Mobile		
	License Nr.		Federation

RED RIDER	Name		
	1st name		Nat
	Address		
	E-mail		
	Mobile		
	License Nr.		Federation

1. RESPONSIBILITY

The participants (sponsors, riders, owners and owner-riders of vehicles) take part in the event at their own risk. They bear the sole responsibility regarding civil and penal codes for damages caused by them or the vehicle in their use. If the rider himself is neither the owner nor the owner-rider of the vehicle used by him during the competition, he releases those persons listed in the following liability waiver from all claims by the owner and the owner-rider of the vehicle or submits, together with the entry form, a corresponding waiver from the owner or owner-rider of the vehicle.

2. ENTRY FEE

By submitting the Entry Form, the Participants pledge to pay by bank transfer an entry fee of: EUR 1.900,00 exclusive of taxes per team per event (upon presentation of VAT liability proof).

3. ACCOUNT HOLDER

PHILIBERT ET ASSOCIES

IBAN: FR76 1027 8116 0800 0201 4091 958

SWIFT/BIC : CMCIFR2A

By submitting the entry form, the participants (sponsors, riders, owners and owner-riders of vehicles) waive all rights to legal action and recourse for any accident or damage incurred in conjunction with the event against:

- The FIM, the FMNR, their president, members, employees and officials;
- Member-clubs of the FMNR and their sub-organizations;
- Organizer, his/their representatives, stewards and assistants;
- The owner(s) of the property used for the event including structures and installations on it, the administration of the circuit used for the event, its representatives and assistants;
- The participants and their attendants as well as against his/their own assistants in so far as a race or special tests for attaining high-speeds or best times are concerned.
- Authorities, race services and any other organizations or corporate or natural bodies involved in the organization of the event, in so far as the accident or damage did not occur through intent or gross negligence.

This agreement will take effect on all parties involved with the submission of the entry form to the organizer.

The undersigned recognizes the above restrictions and commits himself to comply strictly with them. If an injury occurs or is noticed during the event or if the rider's health has been affected such that his fitness for continuing in the motorcycling competition has been put in question, the undersigned – with regard to the security risk also resulting for third parties – releases the doctors in attendance from their obligation to professional secrecy towards the FMNR and towards the officials carrying responsibility at the event (Doctor of the event, Clerk of the Course, Sporting Steward) respectively.

DATE _____

SIGNATURE

TEAM MANAGER
